

# HORSE WEIGHER SCALES

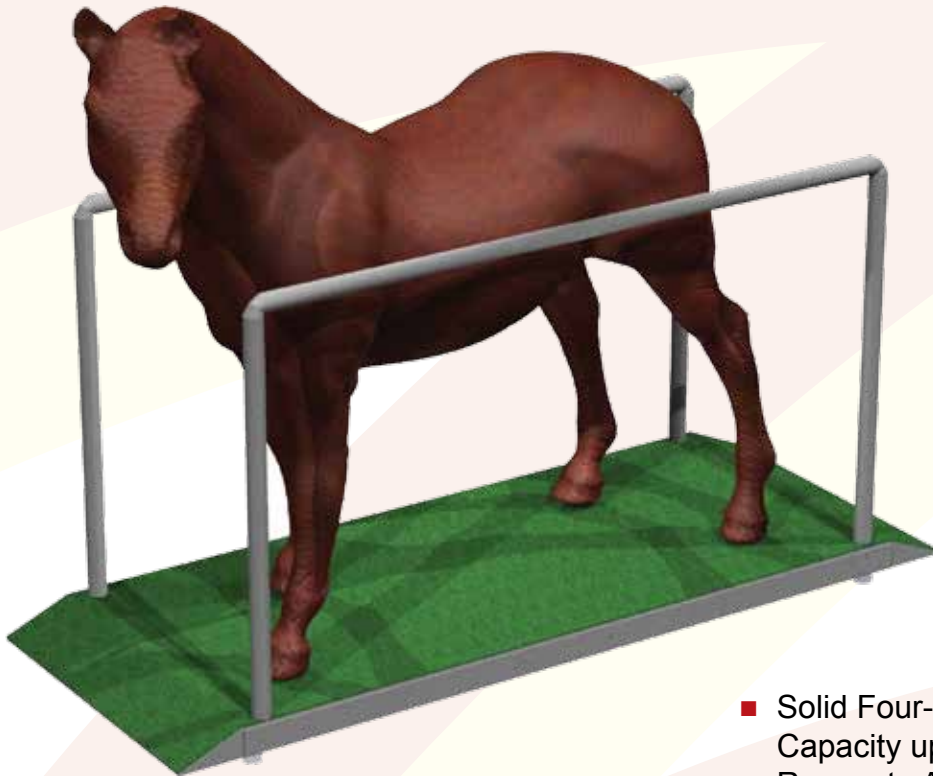

FRONT PANEL VIEW

NON-TRADE FOR  
CHECK-WEIGHING

## DIMENSIONS

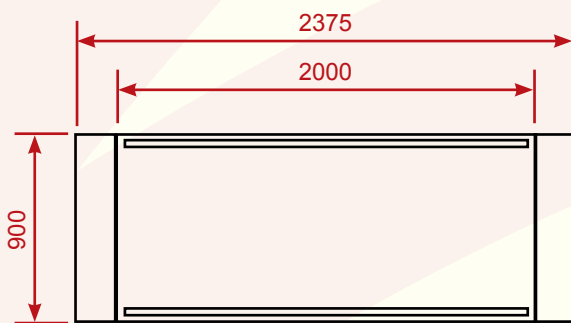

TOP VIEW

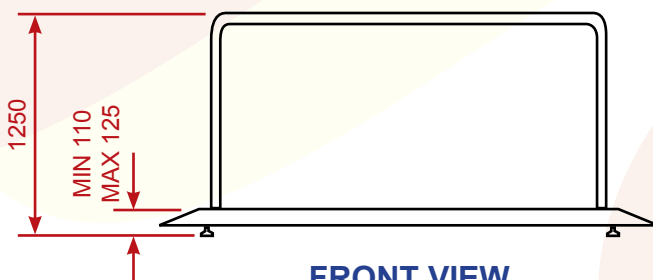

FRONT VIEW

## FEATURES

- Solid Four-Loadcell Design, Digital Scale Capacity up to 1500kg
- Ramps to Access the Platform from Both Directions
- Synthetic Grass Surface
- One or Two Rails to Guide Animals During Use

## OPTIONS

- Finishes
- Sizes
- Rails
- Cage Construction (Upon Request)
- Surface materials

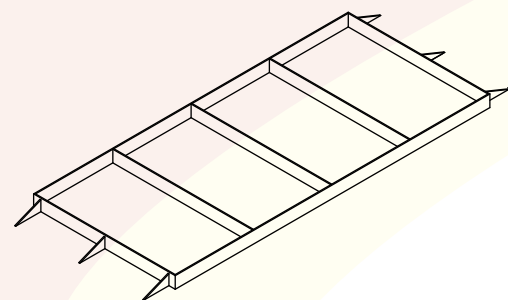

SKELETAL FRAME  
(TOP PLATES REMOVED)

**Accuweigh Pty Ltd**

BROCHURE: AW346 | REVISION: G12

WESTERN AUSTRALIA (HEAD OFFICE):  
PHONE: (08) 9259 5535

SOUTH AUSTRALIA OFFICE:  
PHONE: (08) 8447 5011

NEW SOUTH WALES (SYDNEY) OFFICE:  
PHONE: (02) 9728 4877



[www.accuweigh.com.au](http://www.accuweigh.com.au)

VICTORIA OFFICE:  
PHONE: (03) 9548 5554

NEW SOUTH WALES (NEWCASTLE) OFFICE:  
PHONE: (02) 4966 8900

QUEENSLAND OFFICE:  
PHONE: (07) 3265 5520